

ProFin[®] DP11/21/30

11mm, 21mm and 30mm flexible drainage profile and 90° corner profile for balconies, patios and terraces.

DESCRIPTION

High-performance powder-coated aluminium drip/drain end profile and corner unit for use with Gutjahr external tiling systems from BAL. Can be combined with ProFin[®] BL push-on facing plates for build-up up to 79 mm high. For full installation advice and technical assistance then please refer to Part A Technical Design Guides or contact the BAL TECHNICAL ADVISORY AND SPECIFICATION SERVICE .

Product Properties and Benefits

- Combined drainage and separating profile.
- New generation of edge profile with non-punched leg for safe, simple waterproof attachment of seals in combination with the DiProtec[®] KV-AB sealing tape.
- Drainage holes for shedding surface /seepage water.
- With supports for hanging ProRin[®] balcony gutters.
- Use in combination with ProFin[®] BL push-on face plates for added height up to 79 mm.
- Use as edging with combined AquaDrain[®] T+ or AquaDrain[®] EK drainage mats systems and accessories.

ProFin[®] DP21

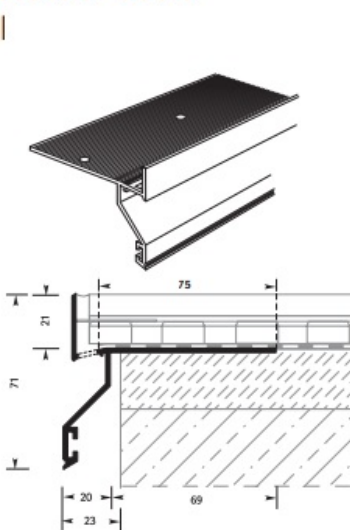

PRODUCT INFORMATION

Composition: ProFin[®] DP11/DP21/DP30 profiles and Corner 90° are constructed from power coated aluminium.

Colour: Alumetallic. Other colours available on request.

Size: Length is 3 m. 1 corner unit = 185 mm x 185 mm

Additional Information:

- Combine products to produce the desired height See page 2 graphic.)

ProFin[®] DP21

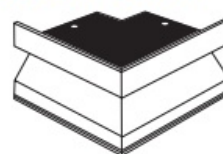

ProFin[®] DP30

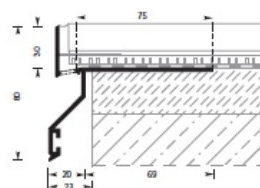



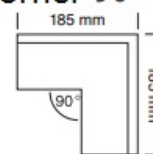

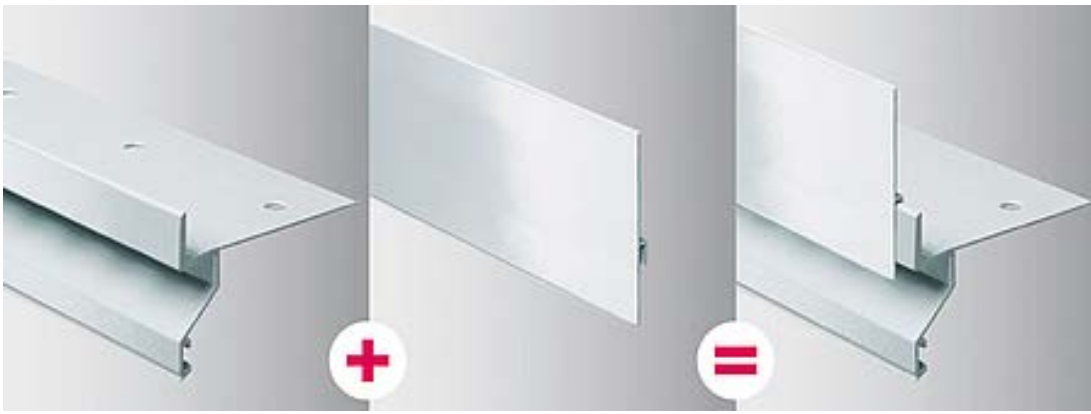



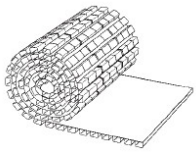

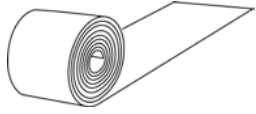
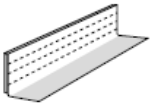

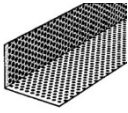
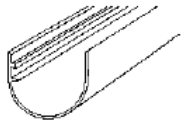

Corner 90°





OPTIONAL SYSTEM COMPONENTS

<p>AquaDrain® EK or T+ drainage mat</p> 	<p>DiProTec® AB-KV sealing tape</p> 	<p>AquaDrain® SK joint tape</p> 	<p>AquaDrain® Edge insulation tape</p> 
<p>AquaDrain® TM or FLEX drain grate</p> 	<p>AquaDrain® Lochwinkel screed angle</p> 	<p>ProRin® BR guttering</p> 	<p>ProFin® DP edge profile and BL facing plate</p> 
<p>BAL Tank-it</p> 	<p>MorTec® DRAIN</p> 	<p>BAL Quickset Cement</p> 	<p>BAL Rapidset Flexible Fibre</p> 
<p>BAL Stone and Tile PTB</p> 	<p>BAL Micromax2 Grout</p> 	<p>BAL Micromax Sealant</p> 	<p>MorTec® SOFT silicone sealant</p> 

N.B Please consult BAL Technical Advisory and Specification Service (TAS) or a member of the BAL specification support team for a full and comprehensive product specification to meet your project requirements.

TECHNICAL ADVISORY SERVICE

For free expert guidance on use of this product, or any aspect of tiling, contact the BAL TECHNICAL ADVISORY AND SPECIFICATION SERVICE on Tel: 01782 591120 or 0845 600 1 222 or Fax: 01782 591121.

SHELF LIFE

No shelf life when stored under normal conditions..

Protect from frost, damp and sunlight.

6 YEAR GUARANTEE

Since 1990, GUTJAHR has been the only manufacturer to offer extended warranties for its drainage systems, e.g. 6 years for balconies, patios and outdoor steps with AquaDrain® drainage.

No liability can be accepted for any loss or damage arising from incorrect use of products or poor workmanship, over which BAL has no control. *Contact BAL Marketing Department for full details.*

CONDITIONS OF SALE

Sold subject to the Company's Conditions of Sale. *Available on request. For sales and technical queries, contact:*

BUILDING ADHESIVES LTD

Longton Road, Trentham, Stoke-on-Trent, ST4 8JB,
England www.bal-adhesives.com

Sales Tel: +44 (0) 1782 591160

Fax: +44 (0) 1782 591131

Technical Tel: +44 (0) 1782 591120 or +44 (0) 845 600 1 222

Fax: +44 (0) 1782 591121

Unit 622, Phase III

Northwest Business Park

Ballycoolin, Dublin 15, Ireland

Tel: +353 (0) 1 880 9210

Fax: +353 (0) 1 880 9211

NOTE: BAL reserves the right to update instructions, technical data and other information at any time without notice.